

For detection of Methane (CH₄), Propane (C₃H₈), Butane (C₄H₁₀), Hydrogen (H₂) and other Combustible Gases

Features

- High-accuracy Catalytic Bead (Pellistor) explosion proof sensor.
- Explosion Proof enclosure
- 4-20mA analog output or optional 0-1V DC, 0-5V DC or 0- 10V DC analog outputs.
- Remote sensor-transmitter on a RS-485 communication network compatible with Acme's popular CEL-Series centralized multipoint/multigas detection and control systems.

Applications

- Energy savings through the intermittent operation of ventilation equipment in enclosed areas.
- Commercial or industrial locations where a sudden build-up of combustible gases may occur.
- Underground parking, boiler rooms, landfills, storage rooms, etc.
- Stand-alone with standard analog outputs for direct connection to the existing Building Management System (BMS) or DDCS.



The Acme Combustible gas sensor-transmitter measures the concentration of the target gas in an enclosed area and produces a proportional analog output signal.

The Acme 40-ST Combustible Gas sensor is explosion proof. The enclosure of the sensor-transmitter is an explosion proof enclosure.

The 40-ST series employs a diffusion-type catalytic bead (pellistor) sensor capable of detecting a broad range of combustible gases. It provides instantaneous detection of these compounds and has long term reliability and trouble free operation.

Designed to act as fixed in-situ safety monitors, the 40-ST sensor-transmitter automatically operates the mechanical ventilation system of a facility upon detection of combustible gases, thereby protecting occupants, personnel and gas-sensitive goods and products.

With the increased use of gas detection in maintenance and industrial facilities, the 40-ST allows installers and users to meet code requirements in an economical fashion using commercial-grade gas detection equipment.

The 40-ST contains all the well-known standard features of ACME's gas detection line; a robust enclosure, the latest sensor technology and state-of-the-art electronics. For more versatile gas detection options, consult the **ACME** binder or website.

Standard unit specifications

- GASES DETECTED:** Methane, Propane, Hydrogen, etc.
- SENSOR TECHNOLOGY:** Catalytic Bead (Pellistor) type.
- SENSING METHOD:** Diffusion.
- POWER REQUIREMENTS:** 24V AC 50/60Hz.
- OUTPUTS AVAILABLE:** 4-20mA
0-1V DC
0-5V DC
0-10V DC
RS-485
- OPERATING TEMP.:** -4°F to 120°F (-20°C to +50°C)*
- HUMIDITY RANGE:** 10-95% RH
- ACCURACY:** +/- 5% of calibrated value
- REPEATABILITY:** 2% of signal
- RESPONSE TIME (T90%):** < 30 seconds
- EXPECTED LIFETIME:** 3 years
- ENCLOSURE:** Explosion Proof - Class 1
- DIMENSIONS:** 11" (L)x Φ4"(D)x 3"(D)
(279mm x 101mm x 75mm)

* Extended temperature range available.

Ordering Information

MODEL NUMBER	GAS DETECTED	RANGE
CH4-ST-XP-X*	Methane	0-40% LEL
C3H8-ST-XP-X*	Propane	0-40% LEL
H2-ST-XP-X*	Hydrogen	0-40% LEL
C4H10-ST-XP-X*	Butane	0-40% LEL
CH4O-ST-XP-X*	Methanol	0-40% LEL

Output Signal and other Options

*X	OUTPUT SIGNAL
420	4-20mA, 2-wire loop-powered, 500Ω max
001	0-1V DC, 10KΩ min
005	0-5V DC, 10KΩ min
010	0-10V DC, 10KΩ min
485	RS-485 for CEL systems only

Explosion Proof mounting arrangements

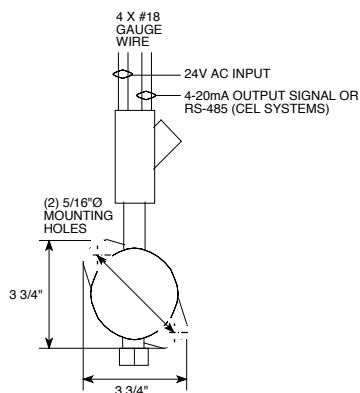

IN THE U.S.A. ACME ENGINEERING PROD. INC.

Trimex Ind. Bldg., PMB #10
2330 State Route 11
Mooers, N.Y. 12958

Tel. : (518) 236-5659
Fax : (518) 236-6941

E-mail : info@acmeprod.com • www.acmeprod.com

IN CANADA ACME ENGINEERING PROD. LTD.

5706 Royalmount Ave.,
Montreal, Quebec
H4P 1K5

Tel. : (514) 342-5656
Fax : (514) 342-3131



REPRESENTED BY: