

Applications

- Process Industry
- Power Industry
- Chemical Industry
- Oil and Gas
- Metals and Mining
- Water and Waste
- Pulp and Paper

Y Strainers

Pressures to 3705 PSIG
Temperatures to 800°F



RATINGS

- ASME Class 150
- ASME Class 300
- ASME Class 600
- ASME Class 900
- ASME Class 1500
- ASME Class 500

FEATURES

- Low pressure drop streamlined design
- Large strainer screens
- Compact end to end dimension
- Fabricated Construction

MATERIALS

- Ductile Iron
- Bronze
- Carbon Steel
- Low Temp Steel
- Chrome Molly
- Stainless Steel
- Other Materials Upon Request

END CONNECTIONS

- Flat Faced
- Raised Face
- RTJ Flanged
- Buttweld
- Threaded (NPT)
- Socketweld
- Sweat

SIZES

- Fabricated - Custom sizes to meet any requirements



FY SERIES FABRICATED Y STRAINERS

PRESSURES TO 6170 PSIG (425 BARG)
TEMPERATURES TO 800°F (427°C)

Custom engineered and fabricated Y strainers
NPT, RF or RTJ, Socketweld and Buttweld connections designed in accordance with ASME B16.34 and B16.5
Standard thru bolt or grooved cover design.
Installation in horizontal or vertical pipelines.
Stainless steel perforated screens are standard
Drain/Blow-off connection furnished with plug

APPLICATIONS

Steam, liquid, gas and oil service
Power industry
Pulp and paper
Chemical industry
Process Equipment
Metal & Mining
Water & Waste

APPLICABLE CODES

Designed/Manufactured to meet ASME B31.1, B31.3 or B31.4 and/or ASME Section VIII, Div. 1.
Canadian Registration Numbers (CRN) available
Welders certified to ASME Section IX

MODELS

FY-1 : Standard
FY-Z : Custom Configuration

OPTIONS

Other materials, sizes and/or configurations
Quick Opening covers – See Page
Other screen, mesh or wedgewire – See Page
Vent and/or differential pressure connections
“U” stamped vessels
NACE MRO10-75 Certification
External/Internal coatings
600# flange rating and higher
Gooved end connections
Oxygen cleaning
Contact Factory for other Options

FY Series Ordering Code

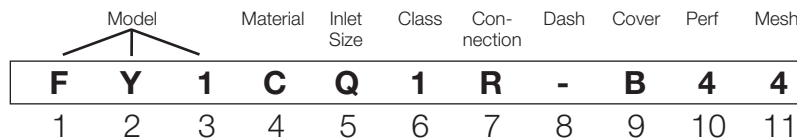

Model - Position 1-3

FY1 - Standard
FYZ - Custom Configuration

Material - Position 4

C - Carbon Steel
L - Low Temp CS
V - 304 SS
T - 316 SS
T - 316 SS
M - Monel
H - Hastelloy
Z - Other

Inlet Size -

Position 5
H - 2"
J - 2-1/2"
K - 3"
M - 4"
N - 5"
P - 6"
Q - 8"
R - 10"
S - 12"
T - 14"
U - 16"
V - 18"
W - 20"
X - 22"
Y - 24"
1 - 28"
2 - 30"
3 - 36"
4 - 40"
Z - Other

Class - Position 6

1 - 150
3 - 300
4 - 600
5 - 900
6 - 1500
7 - 2500
Z - Other

Connection - Position 7

B - Buttweld¹
F - Flat Face Flange
G - Grooved
N - NPT
J - Ring Joint Flange
R - Raised Face Flange
K - Socket Weld
Z - Other

1. For Buttweld connection please specify mating pipe schedule.

Dash - Position 8

Cover - Position 9
B - Bolted
C - Bolted w/C-Clamp
D - Bolted w/Davit
J - Bolted w/Hinge
G - Grooved
H - T - Bolt Hinged
T - Threaded Hinged
Y - Yoke Hinged
Z - Other

Perf - Position 10

304SS Material Standard²
A - None
B - 3/64"
1 - 1/32"
2 - 1/16"
3 - 3/32"
4 - 1/8"
5 - 5/32"
6 - 3/16"
7 - 7/32"
8 - 1/4"
9 - 3/8"
Z - Other

2. For other screen materials, contact factory.

Mesh² -

Position 11
A - None
1 - 10
2 - 20
3 - 30
4 - 40
5 - 50
6 - 60
7 - 80
8 - 100
9 - 120
Z - Other

FY SERIES FABRICATED Y STRAINERS

SPECIFICATION

Y Strainer shall be designed and manufactured to meet ASME B31.1, ASME B31.3 or ASME B31.4 and/or ASME Section VIII Div. 1. The Strainer body shall be fabricated steel or other specified material. The screen shall be size _____ perf Stainless Steel. The strainer shall have a bolted cover furnished with a drain connection and plug as standard. The strainer shall have an inlet size of _____ and Open Area Ratio of _____. The Y Strainer shall be ACME FY- ____ Series.

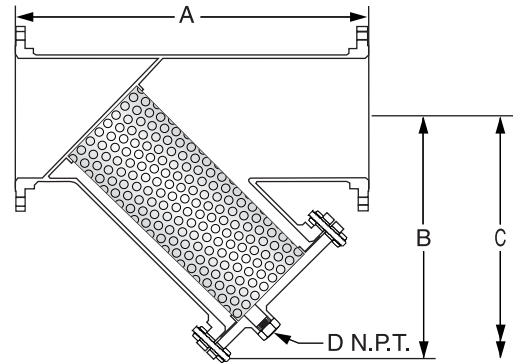

Shown with Bolted Cover

MATERIALS OF CONSTRUCTION

(Carbon Steel shown*)

Shell & Nozzles	SA53S/B / A106-B
Flanges	SA105
Coupling/threadolet	SA105
Plug	SA105
Screen Retainer Ring	A36
Screen ¹	304 SS
Gasket ¹	304 SS Spiral Wound
Stud	SA193-B7
Nut	SA194-2H

* Other Materials Available. Consult Factory

1. Recommended Spare Parts

Materials specification will change when NACE MR01-75 is specified.

Connections*:
2-24" NPT, Socketweld,
RF, FF, RTJ or Buttweld

* For additional sizes consult factory.

SCREEN OPENINGS

SIZE	STANDARD SCREEN	MATERIALS
2"-12"	1/8" Perf	304 SS
14"-24"	3/16" Perf	304 SS

DIMENSIONS inches (mm)

AND WEIGHTS pounds (kg)

150# Shown - Consult Factory for other ratings

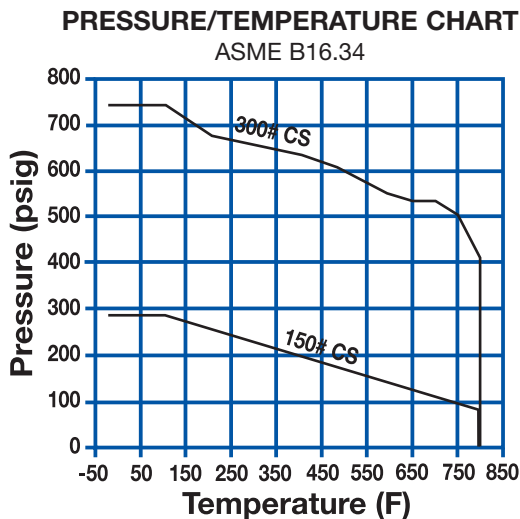

For Quick Opening Covers Ratings see page

For higher pressure classes and other materials, consult factory.

SIZE	A	B	C	D	WEIGHT	
					Cover	Unit
2 (50)	10 ¹³ / ₁₆ (275)	8 ¹ / ₄ (210)	13 ¹ / ₄ (337)	1/2 (15)	5 (2)	28 (13)
2 ¹ / ₂ (65)	13 ³ / ₈ (340)	10 ¹ / ₄ (260)	16 ⁷ / ₁₆ (418)	1 (25)	9 (4)	81 (37)
3 (80)	13 ³ / ₈ (340)	10 ¹ / ₄ (260)	16 ⁷ / ₁₆ (418)	1 (25)	9 (4)	81 (37)
4 (100)	14 ³ / ₄ (375)	10 ¹ / ₂ (267)	16 ³ / ₄ (425)	1 ¹ / ₂ (4)	17 (8)	85 (39)
5 (125)	17 ¹ / ₄ (438)	12 ¹ / ₂ (318)	20 (508)	1 ¹ / ₂ (40)	20 (9)	110 (50)
6 (150)	22 (559)	14 (356)	22 ⁷ / ₁₆ (570)	2 (50)	26 (12)	145 (66)
8 (200)	24 (610)	17 ³ / ₄ (451)	28 ⁷ / ₁₆ (722)	2 (50)	45 (20)	256 (116)
10 (250)	31 ¹ / ₂ (800)	22 (559)	35 ¹ / ₄ (895)	2 (50)	70 (32)	380 (172)
12 (300)	32 ³ / ₄ (832)	25 (635)	40 (1016)	2 (50)	110 (50)	700 (317)
14 (350)	39 ³ / ₄ (1010)	27 (686)	43 ¹ / ₄ (1099)	2 (50)	140 (63)	750 (340)
16 (400)	45 ¹ / ₄ (1149)	30 ⁷ / ₈ (784)	49 ¹ / ₂ (1257)	2 (50)	180 (82)	905 (410)
18 (450)	48 ¹ / ₂ (1232)	33 ⁷ / ₈ (861)	54 ¹ / ₄ (1378)	2 (50)	220 (100)	1125 (510)
20 (500)	53 ³ / ₄ (1365)	39 (991)	62 ¹ / ₂ (1588)	2 (50)	285 (129)	1415 (641)
24 (600)	64 (1626)	44 (1118)	70 ¹ / ₂ (1791)	2 (50)	430 (195)	1825 (827)

FY SERIES

FABRICATED Y STRAINERS

PRESSURE DROP VS FLOW RATE

Water Service, Clean Basket, 1/32" - 1/4" Perforated Screen*

(Sizes 2" - 16")

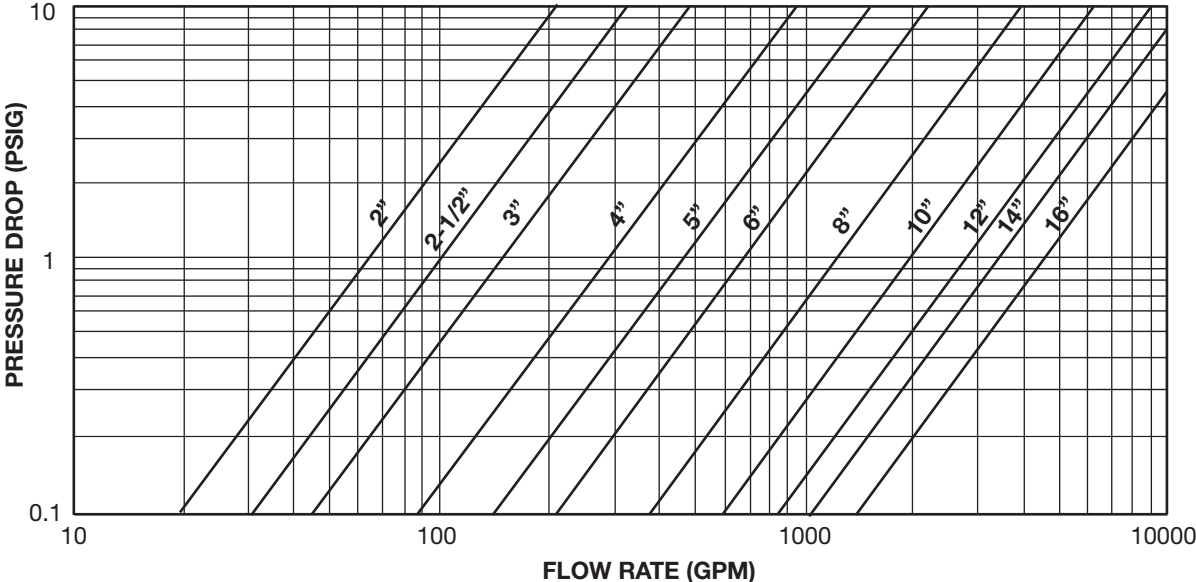

* For Gas, Steam or Air service, consult factory.

FY SERIES

FABRICATED Y STRAINERS

OPEN AREA RATIOS

with Standard Perforated Screen

Size	Perf. Diameter (inches)	Opening %	Std Pipe Nominal Area (in ²)	Gross Screen Area (in ²)	Free Screen Area (in ²)	Open Area Ratio (OAR)
2	1/8	40	3.4	39	16	4.6
3	1/8	40	7.4	77	31	4.2
4	1/8	40	12.7	135	54	4.2
5	1/8	40	20.0	160	64	3.2
6	1/8	40	28.9	215	86	3.0
8	1/8	40	50.0	375	150	3.0
10	1/8	40	78.9	545	218	2.8
12	1/8	40	113.1	785	314	2.8
14	3/16	50	140.5	900	360	2.6
16	3/16	50	185.7	1210	484	2.6
18	3/16	50	237.1	1560	624	2.6
20	3/16	50	294.8	1950	780	2.6
24	3/16	50	429.1	2765	1106	2.6

OAR = Free Screen Area / Inlet Area

Free Screen Area = Opening % x Gross Screen Area

Values shown are approximate. Consult factory for exact ratios.