

TWINSET STAND-ALONE DUAL GAS MONITOR

Bull TW-ECH
January 2009

CO-CO (Carbon Monoxide), CO-NO₂ (Nitrogen Dioxide), CO-CH₄ (Methane),
CO-C₃H₈ (Propane), CO-H₂ (Hydrogen)

Features

- High-accuracy Electrochemical Cell sensor for toxic gases and Catalytic (Pellistor) for flammables
- 3 or 4-stage SPDT relay outputs with LED status indicators
- NEMA 3 Robust Enclosure
- Microprocessor-based control
- 10-Step Bar-Graph Display of gas levels
- Programmable time delays to avoid nuisance alarms
- Optional 4-20mA, 0-1V DC, 0-5 V DC or 0-10V DC analog output
- Optional remote sensor

Applications

- Versatile and cost-effective way of detecting two gases simultaneously by a single Controller
- Energy savings through the intermittent operation of ventilation equipment in enclosed areas
- Commercial or industrial locations where a sudden build-up of toxic and/or flammable gases may occur
- Car Parking and Bus Maintenance Garages, Tunnels, Warehouses, Factories, Food Processing and Bottling Plants, Wastewater Treatment Plants, Steel Mills, Cryogenic laboratories and Incineration Rooms
- Stand-alone with relay outputs or analog outputs for direct connection to the existing Building Management System (BMS) or DDCS



The Acme TwinSet and its microprocessor-based system features a high quality stand-alone controller providing all the necessary hardware for the continuous monitoring of two gasses in the following combinations: CO/CO, CO/NO₂, CO/COMB. This unit is primarily geared towards providing alarm activated relays for simple applications such as small parking garages.

The TwinSet employs the best sensing technologies available: electrochem and pellistor (catalytic combustion) cells. These quality components provide virtually instantaneous detection of targeted gasses and deliver long-term trouble-free operation. The main body of the TwinSet detects carbon monoxide build up, while the remote sensor monitors either CO, NO₂ or a combustible.

Installed within the monitored space, the TwinSet monitors targeted gas concentration rates and automatically operates the mechanical ventilation system of a facility. Upon detection of low levels of hazardous and flammable gases the ventilation system is energized thereby protecting occupants, personnel and gas-sensitive goods and products.

The TwinSet contains all the well-known standard features of ACME's gas detection line; a robust enclosure, the latest sensing technologies and state-of-the-art electronics.

Standard unit specifications

GASES DETECTED:	CO, NO ₂ , H ₂ , CH ₄ (Methane), C ₃ H ₈ (Propane)
SENSOR TECHNOLOGY:	3-Electrode Electrochemical Cell
TOXIC:	Catalytic Pellistor
FLAMMABLE:	
SENSING METHOD:	Diffusion
POWER REQUIREMENTS:	24V or 120V or 240V 50/60HZ
OPTIONAL:	4-20 mA, or one of the following 0-1V DC 0-5V DC 0-10V DC
OPERATING TEMPERATURE:	-4°F to 120°F (-20°C to +50°C)*
HUMIDITY RANGE:	15-90% RH
ACCURACY:	+3% /- 5% of Calibrated value (electrochemical sensors) +/- 1 L.E.L (pellistor)
REPEATABILITY:	2% of Signal
RESPONSE TIME (T90%):	40 seconds
EXPECTED SENSOR LIFETIME:	<u>Electrochemical</u> 5 years for CO only 2 years for other gases <u>Pellistor</u> 3 years
MAIN ENCLOSURE:	NEMA 3 Polystyrene Grey Surface Mounting
MAIN ENCLOSURE DIM.:	6" x 6" x 4" (152mm x 152mm x 102mm)
APPROVALS:	CAN/CSA C22.2 No. 61010-1:2004 ANSI/UL 61010-1:2004

Ordering Information

MODEL NUMBER	GASES DETECTED
CC-TWR**-X**-Y**	CO-CO
CN-TWR**-X**-Y**	CO-NO2
CH-TWR**-X**-Y**	CO-H2
CM-TWR**-X**-Y**	CO-CH4
CP-TWR**-X**-Y**	CO-C3H8

Power Supply Options

**X	LINE VOLTAGE
24	24 V 50/60 HZ
120	120V 50/60 HZ
240	240V 50/60 HZ

**Y= 1 Bar Graph

**Y= 0 or Leave empty for no Bar Graph

**R= 3 For 3 relays

**R= 4 For 4 relays

Typical Wiring Diagram

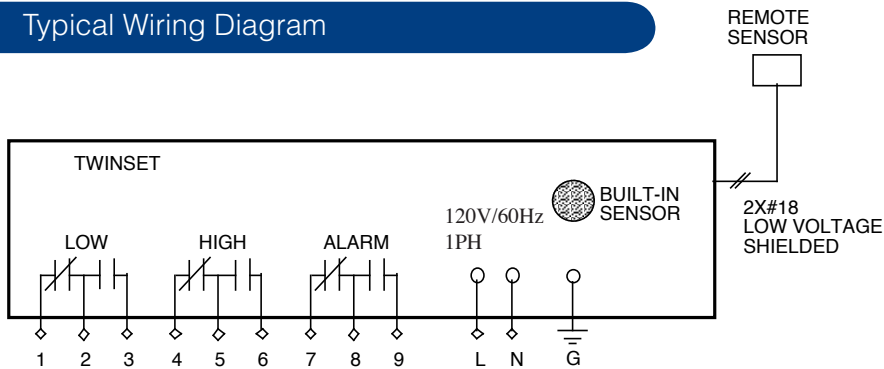

IN THE U.S.A.

ACME ENGINEERING PROD. INC.
Trimex Ind. Bldg., PMB #10
2330 State Route 11
Mooers, N.Y. 12958
Tel. : (518) 236-5659
Fax : (518) 236-6941

E-mail : info@acmeprod.com • www.acmeprod.com

IN CANADA

ACME ENGINEERING PROD. INC.
5706 Royalmount Ave.,
Montreal, Quebec
H4P 1K5
Tel. : (514) 342-5656
Fax : (514) 342-3131



REPRESENTED BY: